

# MULTICHANNEL HIGH QUALITY SYSTEM



**SNMP**  
integrated  
Version 1

HIGH QUALITY SYSTEM

## **STC096M - Multichannel Transcoder** **8PSK/QPSK to QAM/RF**

**up to 30 8PSK/QPSK to QAM/RF channels in one 4RU subrack**

- **Modular Headend system featuring Hot Swap technology**
- **4RU subrack with central control unit with power supply for all modules**
- **STC096 - Twin 8PSK/QPSK to QAM transcoding modules**
- **Each STC096 module transcodes two 8PSK/QPSK signals into two QAM/RF channels**
- **Frequency agile outputs 45 - 862 MHz**
- **DVB and DigiCipher II support**
- **Supports ITU J.83 Annex B and DVB-C QAM standards**
- **Excelent system performance and quality**
- **Flexible local and remote configuration & SNMP monitoring**

## Professional Headend Solutions

### Unique headend management and flexible installation

#### Flexible management

The modules can be easily adjusted, managed and controlled via the central control unit (HCB 200 Headend Controller). All settings can be done locally or remotely without additional software.

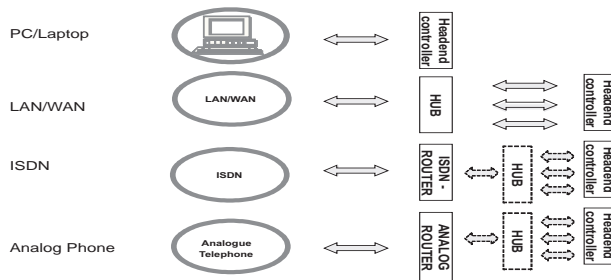

#### HCB 200 - Headend Controller

- Central control unit for entire headend system
- Contains a power supply unit, operating front panel keypads and display, WEB - Server & data interfaces
- Automatic power supply redundancy optional
- Management locally via front panel keypads or with PC/Laptop via the Ethernet Interface
- IP - based remote operation/management via integrated WEB - Server
- SNMP function optional available

#### POWER SUPPLY REDUNDANCY OPTION

Additional power supply unit will be added. All modules will be powered by the headend controller and via the power supply unit BEB 200. An automatic power supply redundancy layout is implemented.

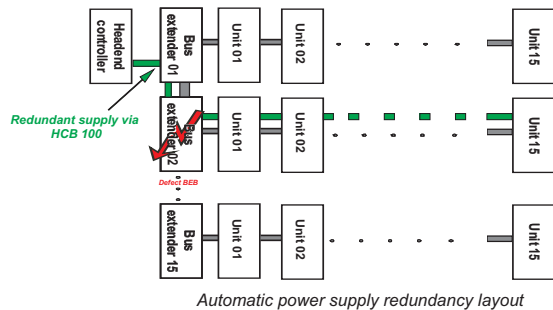

#### BEB 200 - Power Supply / Bus Extender

- BUS extension & power supply module
- Addressing and current supply of one line
- Automatic power supply redundancy in connection with Headend Controller (HCB 200)
- 100% power supply redundancy by usage of two BEB 200 possible
- Operating status can be called via the Headend Controller (HCB 200)

#### Flexible and stable mounting

The system modular concept is convenient for various and space efficient installation & mounting like direct wall or into 19" cabinets mounting.

BSR 008 is a 19" subrack for max. 8 modules. Contains one Headend Controller HCB 200 and up to 7 modules STC096 (14 channels)

MSR 016 is a 19" subrack for max. 16 modules (front & rear plug-ins).

Contains one Headend Controller HCB 200 and up to 15 modules STC096M (30 channels)

#### BSR 008 / 19" - Subrack

- BSR 008 subrack can contain max. 8 modules
- Sufficient for 19" cabinets or direct wall mounting



#### MSR 016 / 19" - Subrack

- Professional subrack for max. 16 modules (front & rear plug-ins)
- Fits into any 19" cabinet
- Professional, stable and robust design



### STC 096 **DVB-S2 & DC II**

#### TWIN 8PSK/QPSK to QAM TRANSCODER Module

The **STC 096 TWIN 8PSK/QPSK to QAM Transcoder** is a must have unit for any cable operator in their digital network.

The unique TWIN channel processing technology allows transcoding of two 8PSK/QPSK (DVB & DigiCipher® II) signals into the digital cable standard QAM. It is equipped with a high performance Upconverter offering fully agile RF outputs (45...862 MHz) with state-of-the-art output values.

This innovative and unique solution is one of the most cost- and space efficient digital headend system with excellent performance and a user friendly, remote-controllable management interface.

- **TWIN QAM Transcoder Module especially for HDTV applications (MPEG-4)**
- **Dual 8PSK/QPSK IN & Dual Agile QAM/RF OUT (45...862 MHz)**
- **Supports ITU J.83 Annex B and DVB-C QAM standards**
- **Modular design allows installation into any 19" cabinet**
- **Various transport stream processing opportunities (NIT, CAT-Filter, Operator-ID, PID-Filter, Network-ID, etc.)**
- **Excellent and high quality values for MER, output level...**
- **Easy and flexible local and remote control & operation**



## TECHNICAL SPECIFICATIONS

### ■ STC 096 TWIN 8PSK/QPSK to QAM Transcoder Module 2 x 8PSK/QPSK ⇒ 2 x QAM/RF

|   |   |   |  |
|---|---|---|--|
| <b>INPUT</b><br>Frequency range<br>Frequency step size<br>Capture range<br>AGC - Level range<br>Impedance<br>Connector<br>Return Loss<br>Through loss<br>FEC Decoding<br>LNB power supply | 950...2150 MHz<br>1 MHz<br>± 5 MHz<br>04...34 dBmV<br>75 Ω<br>F<br>14 dB min.<br>1.0 dB<br>VB / DigiCipher® II<br>12 V / 400 mA   | Test signals<br>Measurement signal<br>Max. Output level<br>Level adjustment range<br>Level degree step<br>Channel allocation<br>Output impedance<br>Spurious<br>Return loss<br>Interleaving<br>Error correction / FEC<br>Connector<br>Through loss<br>Output frequency range<br>Bandwidth | according QAM-constellation unmod. carrier (Signal level)<br>30 dBmV<br>10 dB<br>0.5 dB<br>adjacent channel capable<br>75 Ω<br>- 55 dBc<br>≥ 14 dB<br>Conv. I=12<br>Reed Solomon (204;188,8)<br>F<br>1 dB<br>45...862 MHz<br>6 MHz |
| <b>DVB-S2 Demodulator / Decoder</b><br>Modulation<br>Symbol rate<br>Code rate (LDPC)  | 8PSK/QPSK<br>5...30 MSps<br>3/5, 2/3, 3/4, 5/6, 8/9, 9/10<br>1/2, 3/5, 2/3, 3/4, 4/5, 5/6, 8/9, 9/10                              | <b>Operating parameter</b><br>Power consumption   | 12 V (± 0.2 V) / 850 mA  |
| <b>DVB-S / DC II / DTV - Demodulator/Decoder</b><br>Modulation<br>Symbol rate<br>Code rate (Viterbi)  | QPSK<br>1...45 MSps<br>1...30 MSps<br>5...30 MSps<br>1/2, 2/3, 3/4, 5/6, 6/7, 7/8<br>5/11, 1/2, 3/5, 2/3, 3/4, 4/5, 5/6, 7/8      | <b>Physical information</b><br>Operating temperature<br>Weight<br>Dimensions/Size   | - 10...+ 55 °C<br>3.0 lps<br>2" W x 6" D x 12" H   |
| <b>QAM - Output</b><br>QAM Modulation<br>Symbol rate<br>Spectral inversion<br>Carrier suppression<br>Roll off<br>Modulation Error Rate (MER)  | ITU-T J.83 Annex B, DVB-C<br>16, 32, 64, 128, 256 QAM<br>1.725 - 6.956 MSps<br>Auto recognition<br>> 50 dB<br>12, 18 %<br>≥ 40 dB | <b>Management / Current Supply</b><br>Local & Remote Management<br>Addressing & Power Supply  | Via HCB 100 (Headend Controller)<br>Via BEB 100 (Bus Extender)   |

#### ORDERING INFO:

- STC096M-8-N - 8PSK/QPSK to QAM Transcoder; includes: N modules STC096 (2 x N channels) , subrack BSR 008 and Headend Controller module.
- STC096M-16-N - 8PSK/QPSK to QAM Transcoder; includes: N modules STC096 (2 x N channels) , subrack BSR 016 and Headend Controller module.

Contact info: sales@advanceddigital.ca

WEB: www.advanceddigital.ca

TEL: +1 416-479-0480 416-848-0715